

**WELCOME TO:**



# **The Blackburn Point Bridge Project Development and Environment (PD&E) Study**

Alternatives Public Meeting

Thursday, June 11, 2025

4:30 p.m. - 6 p.m.

# TONIGHT'S AGENDA

- PD&E Study Process
- Project Purpose and Need
- Existing Conditions
- Alternatives to be Studied
- Project Schedule
- How to Comment



# PD&E STUDY (NEPA) PROCESS

Project Development & Environment (PD&E) Study following the requirements of the National Environmental Policy Act (NEPA)

- Purpose and Need
- Environmental Studies
- Alternatives Analysis
- Technical Reports
- Public Involvement
- Environmental Document Approval



WE ARE  
HERE



## PROJECT PURPOSE AND NEED

The purpose of the project is to review alternatives to replace the Blackburn Point Bridge (Bridge No. 170064) on Blackburn Point Road (County Road (CR) 789) over the Gulf Intracoastal Waterway in Osprey, Sarasota County, Florida. The need for the project is based on the following criteria:

- Bridge Deficiencies
- Safety
- Modal Interrelationships (ability to accommodate all current means of transportation)



# PROJECT LOCATON AND LIMITS



# PROJECT LOCATON AND LIMITS



# BRIDGE HISTORY

## Blackburn Point Bridge

- Constructed in 1925-26
- One of eight (8) remaining highway swing spans in service in Florida
- Listed on the National Register of Historic Places and the Sarasota County Register of Historic Places
- The PD&E project will follow the requirements of the National Environmental Policy Act (NEPA) and Sarasota County in addressing affects to a historic resource



## BRIDGE DEFICIENCIES

- Structural conditions
  - Steel truss corrosion
  - Piling deterioration
  - Fender system impact damage
- Mechanical conditions
  - Substandard design
  - Component wear and deterioration
  - Outdated equipment well beyond service life
- Electrical conditions
  - Outdated equipment well beyond service life

Many of these issues are the result of insufficient clearance over salt water and inadequate design and construction standards at the time

# BRIDGE DEFICIENCIES

Photographs representative of existing conditions of the swing bridge's main lower truss members



Truss members subjected to tension under truck loading are susceptible to fracture

# BRIDGE DEFICIENCIES

Photographs representative of existing conditions of the swing bridge's main upper truss members

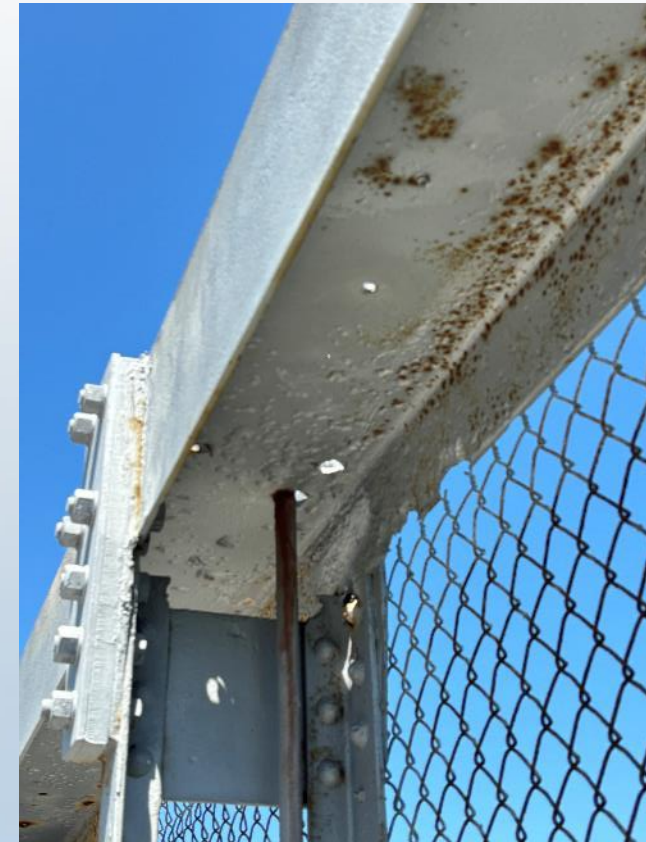

# BRIDGE DEFICIENCIES

Prior Major Repairs:

1981 – Major Repairs  
(hit by barge)

1987 – Major Repairs

1995 – Major Repairs

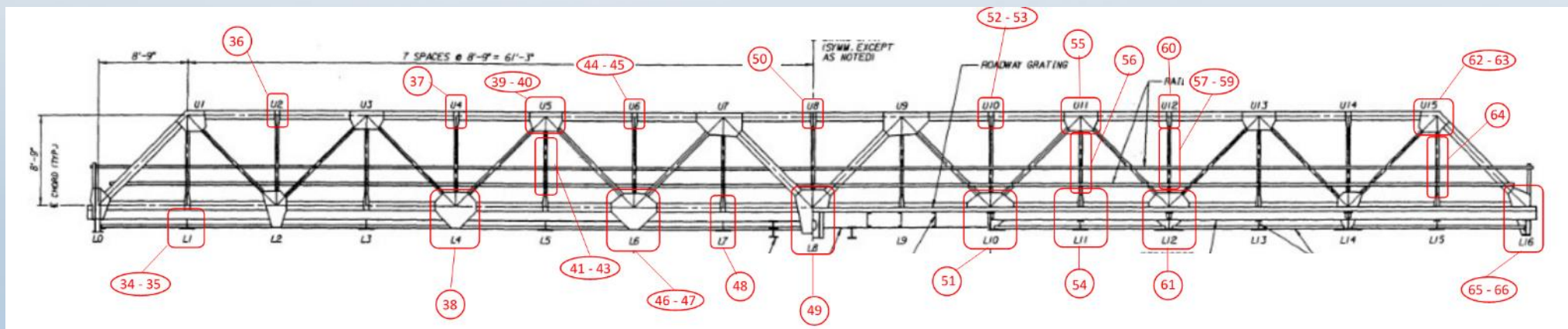

Recommended Truss Gusset Plate Repairs / Replacements (Prepared in 2021)

# BRIDGE DEFICIENCIES

## Ongoing Repairs:

- Pinion shaft was replaced three (3) times in the past four (4) years



- Fender system repairs
- Structural repairs

HISTORY OF RECENT REPAIRS	
YEAR	DESCRIPTION
1997	Replaced manually-operated end toggles with electrically-operative actuator toggles
2006	Riprap and piling rehab
2009	New pivot bearing, new spider assembly, new upper and lower tracks, new rack, new pinion and shaft, new wheels, new elevator wheel assembly, new drive train assembly
2010	Placed 20 CY flowable fill behind SW timber wingwall
2011	Motor replaced
2012	Gusset plates replaced
2012	Pinion shaft replacement emergency repair
2014	End toggle replacements; live load shoes; pivot bearing shim
2016	Drive gear; Gusset plate and truss member retrofits
2019	Gusset plate retrofits ("cheese plates")
2019	Replace drag cables for center pivot
2019	Clean, paint and repair section loss in top chord gusset plates; replace deteriorated rivets
2019	NW quadrant slope protection
2019	Fender repairs
2020	Machinery stringer crack retrofitted
2020	Center bearing cover plate replaced
2020	Fender repair due to boat impact
2020	Stringer at rest pier 1 trimmed to avoid hitting steel nose plate on approach pavement
2021	Replace conduit system on fender
2021	Riprap at NW Wingwall
2022	Center bearing rehabilitated, new pinion shaft, floorbeam retrofits
2023	Repair grid deck welds
2024	Pinion shaft emergency replacement (again) due to deformation. New limit switches.
2025	Pinion shaft emergency replacement (again) due to deformation

REPAIR LEGEND:	
<span style="background-color: #00FF00; border: 1px solid black; display: inline-block; width: 15px; height: 10px;"></span>	Structural
<span style="background-color: #00FFFF; border: 1px solid black; display: inline-block; width: 15px; height: 10px;"></span>	Mechanical
<span style="background-color: #FFFF00; border: 1px solid black; display: inline-block; width: 15px; height: 10px;"></span>	Fender System

# BRIDGE DEFICIENCIES

## Marine Vulnerabilities:

- Existing swing bridge and abutments are not capable of sustaining a direct vessel collision
- The existing bridge low members are within the splash zone, subject to accelerated corrosion due to saltwater and salt laden air



# SAFETY – BRIDGE WIDTH / COMPONENTS

## Bridge Width Deficiencies:

- Substandard clear roadway width of only one, 16-foot-wide travel lane
- Despite frequent daily pedestrian and bicycle use, the bridge does not feature shoulders, sidewalks or bicycle lanes
- Minimum required lane and shoulder widths prescribed by the American Association of State Highway and Transportation Officials (AASHTO) are not met.

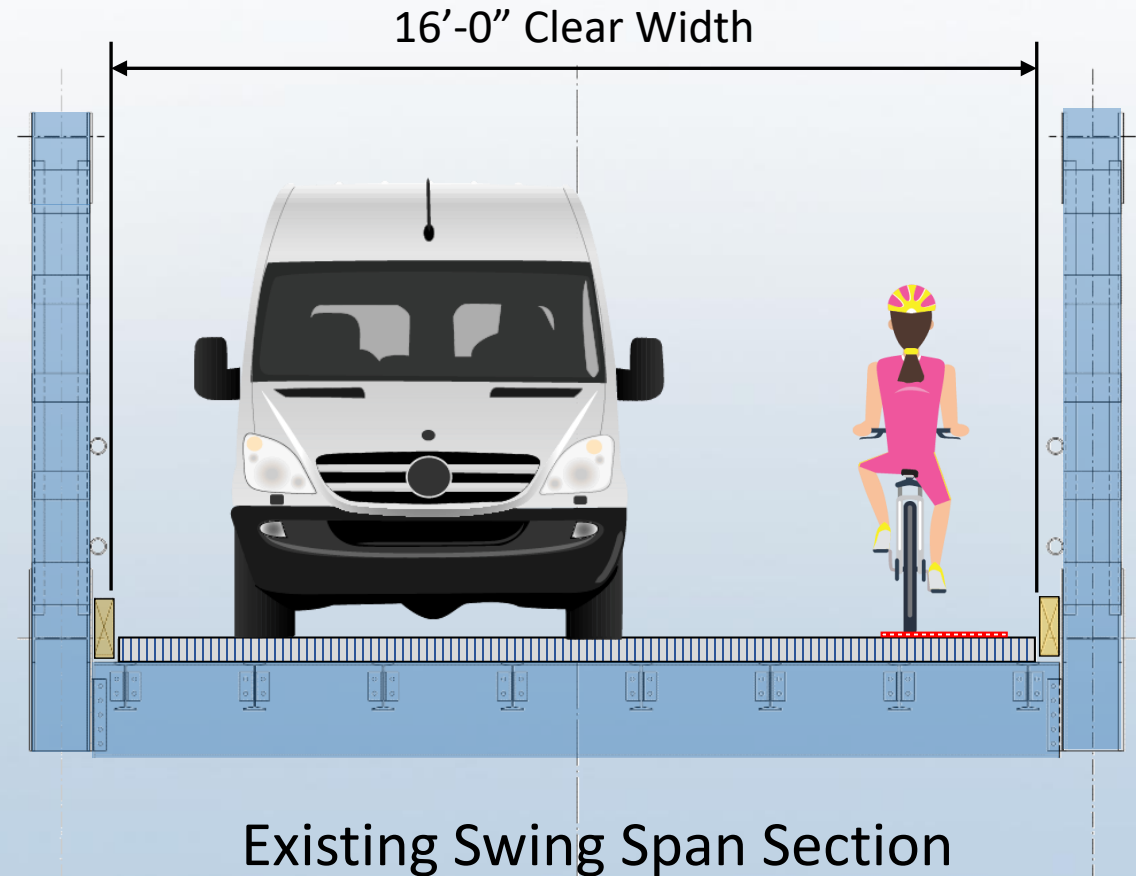

# SAFETY - EVACUATION

## Evacuation:

Existing bridge is important for evacuation during a storm event.

Blackburn Point Road between Casey Key and US 41 is a designated emergency evacuation route.

There is insufficient room available to pass a stalled vehicle on the bridge during an emergency.

Proposed improvements will increase bridge width to provide sufficient room for vehicles to pass a stalled vehicle on the bridge.



# SAFETY – BRIDGE RAILINGS

## **Bridge Railings:**

Existing bridge railings do not meet current standards for pedestrians or bicycles.

Existing bridge railings do not meet current geometric and crash testing safety standards for vehicles.

Proposed improvements will provide bridge railings that meet current safety standards for pedestrians, bicyclists, and vehicles.



# SAFETY - NAVIGATION

## Substandard Navigational Clearances:

The U.S. Coast Guard (USCG) has determined that the existing navigational clearances are an unreasonable obstruction to navigation for the Gulf Intracoastal Waterway.

Existing Navigation Clearances (through the bridge fenders):

- Horizontal – 51 feet
- Vertical – 9.3 feet

USCG Guide Clearances (Gulf Intracoastal Waterway):

- Horizontal – 90 feet
- Vertical – 21 feet



# SAFETY

## Crash History:

Ten (10) crashes without any fatalities were reported within the project area (bridge plus 700 feet either side) from 2019 through 2024.

Two (2) crashes involved pedestrians and bicycles, with the bicycle crash occurring on the bridge and the pedestrian crash occurring west of the bridge.

The addition of pedestrian and cyclist accommodations are proposed for any replacement bridge to enhance safety and mobility for these vulnerable road users.



# MODAL INTERRELATIONSHIPS

## Modal Interrelationships:

There are no sidewalks on the bridge to meet current accessibility requirements established by the Americans with Disabilities Act (ADA).

There are no bicycle lanes on the bridge. The bridge has an open grid metal deck which is problematic for bicyclists. An existing warning sign at each end of the bridge states "Walk Bikes Across Bridge".

Multiple pedestrians and bicyclists cross the Blackburn Point Bridge daily.

The proposed improvements for this project will accommodate bicycles, provide a sidewalk(s), and provide a solid bridge deck for enhanced safety.



# ALTERNATIVE CONSIDERATIONS



## 1. Constrained Site

- 1 Casey Key Fish House
- 2 Casey Key Library
- 3 Blackburn Point Park
- 4 Adjacent Driveways

## 2. Potential Environmental Impacts

- 5 Historic Bridge
- 6 Blackburn Point Park
- 7 Natural Environment

## 3. Maintaining Traffic Through Construction

Detour Route is 10.5 miles via Albee Road

# PROJECT ALTERNATIVES

- No-Build:
  - Retain the existing single-lane bridge and repair as necessary to maintain operation and structural adequacy
- Replace with a new bridge:
  - Bridge types being considered:
    - Swing Span (bob-tailed, machinery on the east side of the channel)
    - Bascule Span (single-leaf, machinery on the east side of the channel)

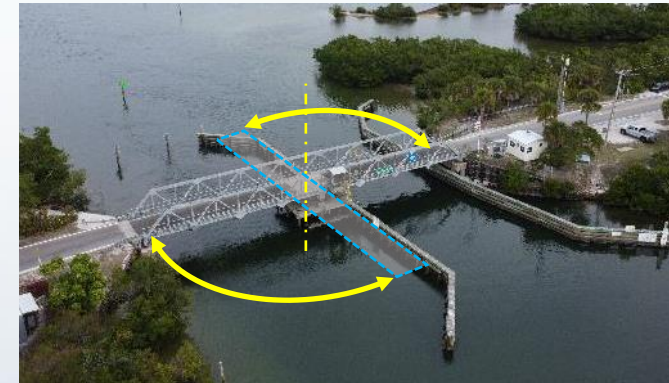

Swing Span



Bascule Span (single-leaf)

# NO BUILD ALTERNATIVE

Repair existing bridge to maintain operation and structural adequacy:

- Annual maintenance including minor repairs
  - Cost based on recent trends, escalated for worsening conditions
- Periodic repairs to structure, machinery, fender system, and electrical systems
  - Cost estimated by grouping work into contracts at five-year increments
  - Each contract to address critical deficiencies anticipated in the next five years
  - First contract to address deteriorated steel, drive machinery, & failing retaining wall

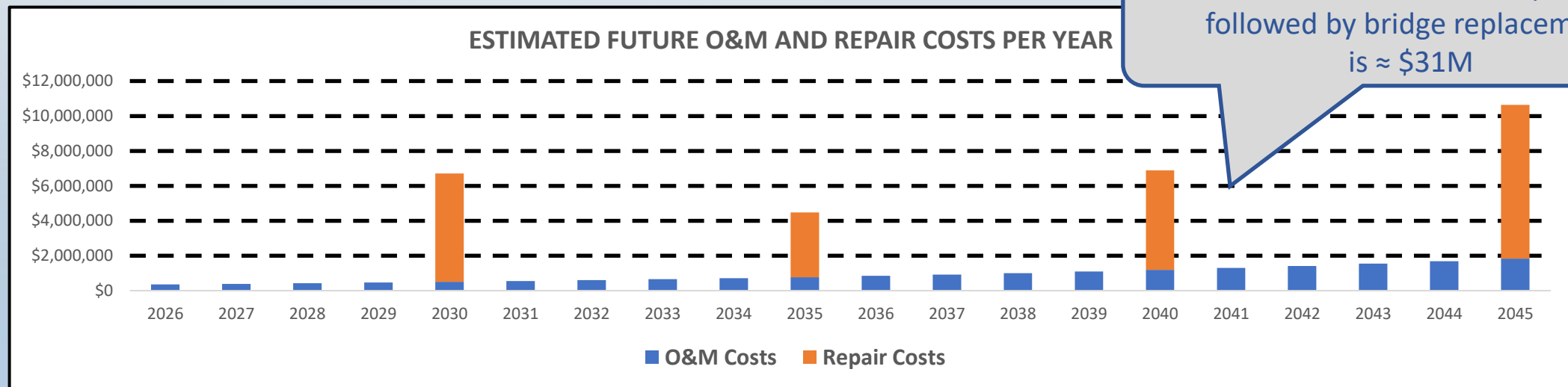

The Present Value of these expenditures followed by bridge replacement is  $\approx$  \$31M

# NO BUILD ALTERNATIVE

Continue repairs until the substructure (piles and pile caps) requires replacement or repairs that require USCG permits<sup>1</sup> – estimated at no more than 10 to 20 years given the current condition state - even with continued repairs and pile jackets

- Current Condition State = 3 – Serious
- Indicates that loss of section, deterioration, spalling, cracking, or other deficiencies have seriously affected primary structural components

<sup>1</sup>Substructure replacement would require USCG permitting which they have previously indicated will not be granted unless the channel width is widened to 90 feet.



# NO BUILD ALTERNATIVE

Anticipated work in the first major repair project (\$6.2 M):

- Replace steel open grid deck & repair sidewalk plate
- Replace deteriorated structural steel member – approx. 20% of the structure
- Blast clean and paint the entire steel structure
- Replace all pile jackets
- Replace damaged fender system wales and pile cluster wraps
- Replace drive motor, drive machinery, and balance wheel assembly
- Install new sheet pile bulkheads

The first repair project will require closing the bridge to traffic for 2 to 3 months



# REPLACEMENT TYPICAL SECTION OPTIONS

Typical Sections under consideration include:

- Single-lane bridge with one sidewalk
- Two-lane bridge with one sidewalk
- Two-lane bridge with two sidewalks

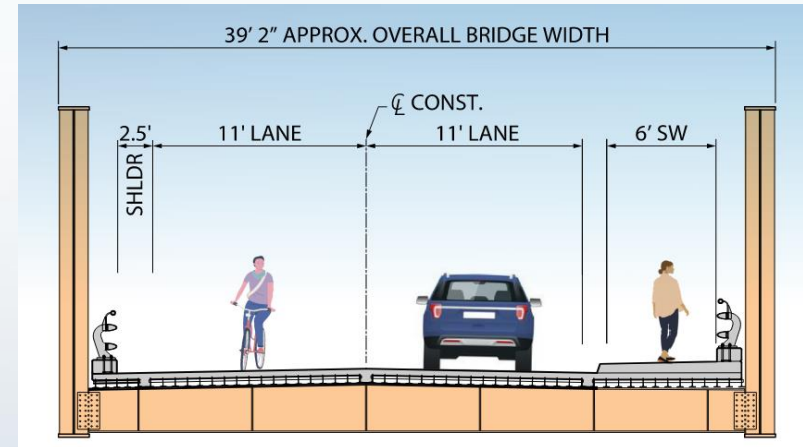

Two-Lane Bridge with One Sidewalk Option

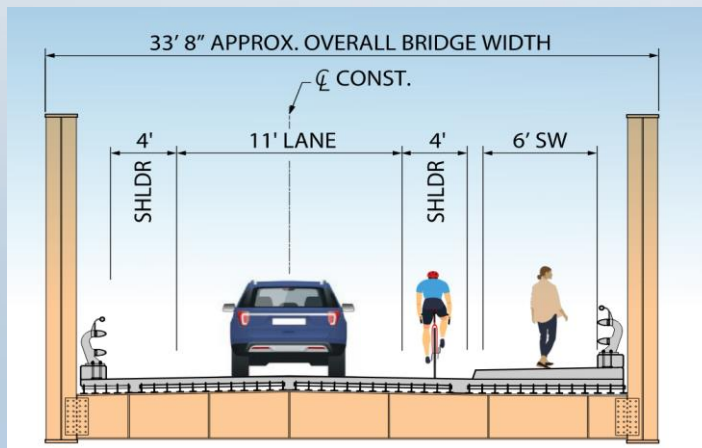

Single-Lane Bridge with One Sidewalk Option

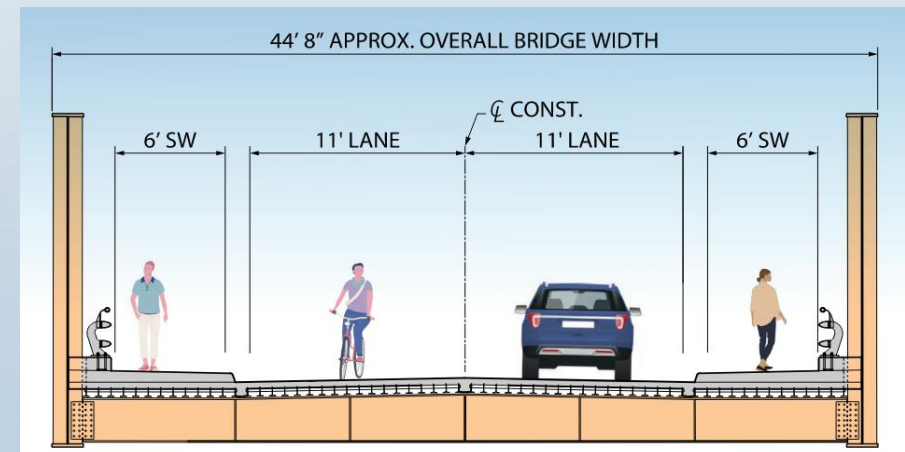

Two-Lane Bridge with Two Sidewalks Option

# REPLACEMENT TYPICAL SECTIONS

## Single-Lane Bridge with One Sidewalk Option:

- 11-foot-wide travel lane
- 4-foot-wide shoulders on either side of the lane
- 6-foot-wide sidewalk on the south side
- Safety barriers

Bridge Girder  
or Truss

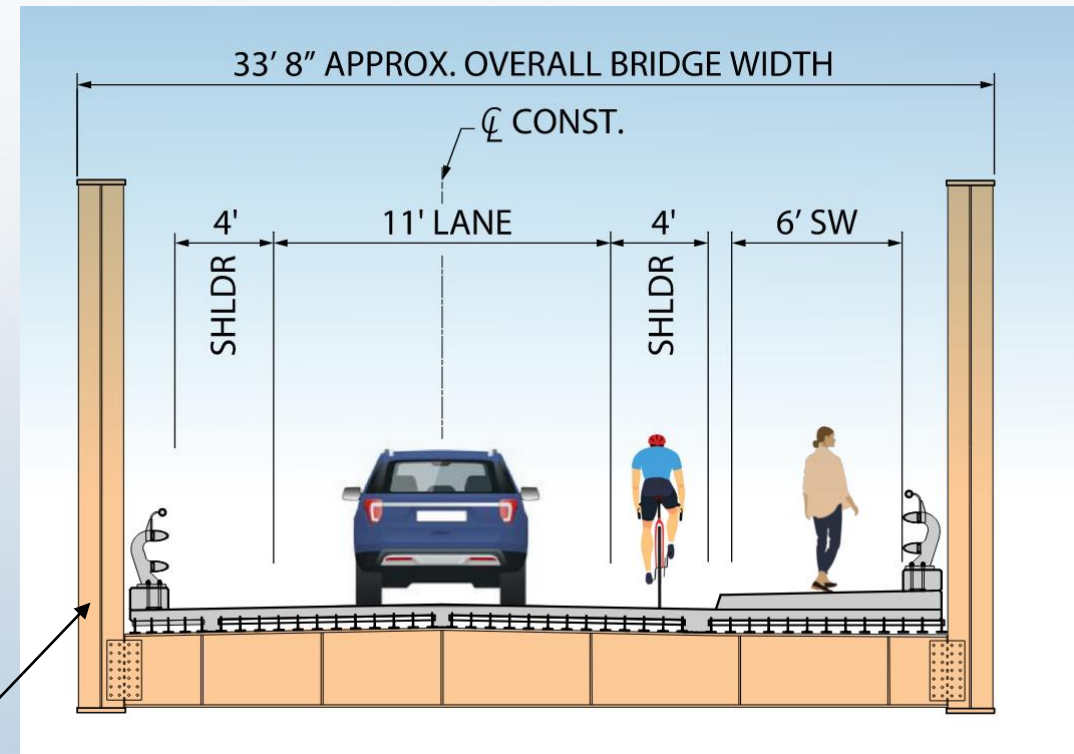

Single-Lane Bridge Option

# REPLACEMENT TYPICAL SECTIONS

## Two-Lane Bridge with Single Sidewalk Option

- 11-foot-wide travel lanes
- 2.5-foot-wide shoulder on the north side
- 6-foot-wide sidewalk on the south side
- Safety barriers

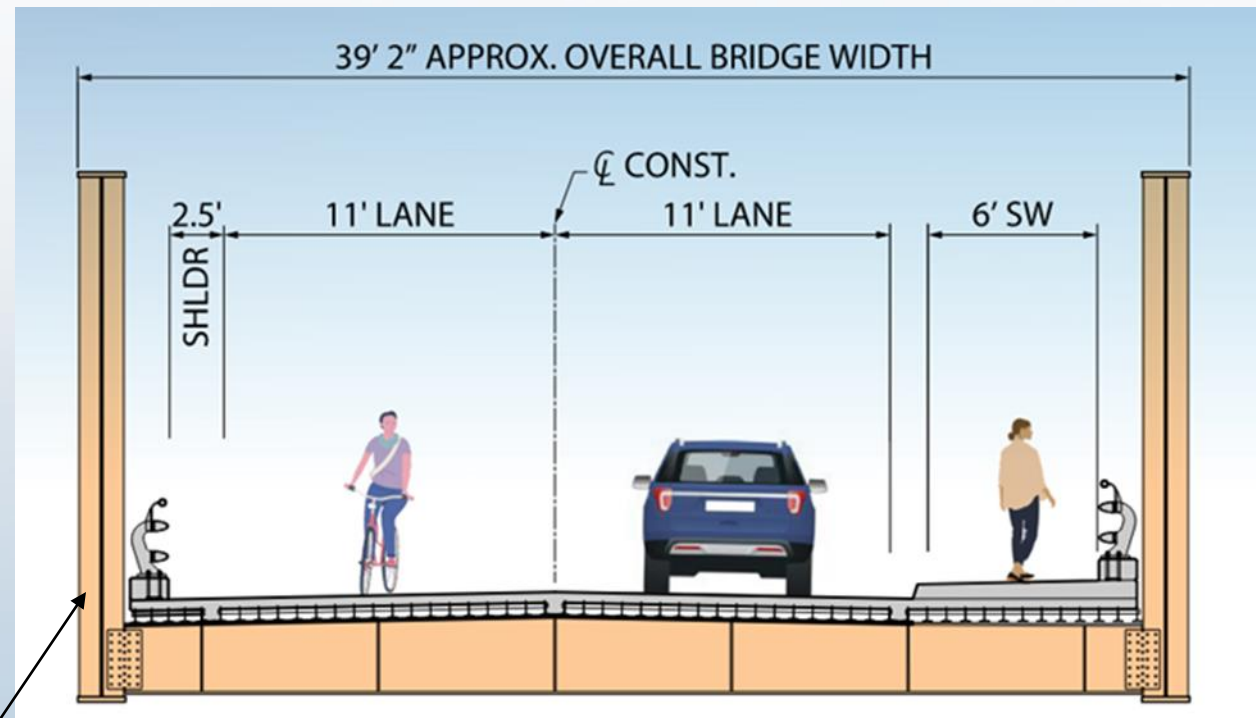

Bridge Girder  
or Truss

Two-Lane Bridge with One Sidewalk Option

# REPLACEMENT TYPICAL SECTIONS

## Two-Lane Bridge with Two Sidewalks Option

- 11-foot-wide travel lanes
- 6-foot-wide sidewalk on the south side
- Safety barriers

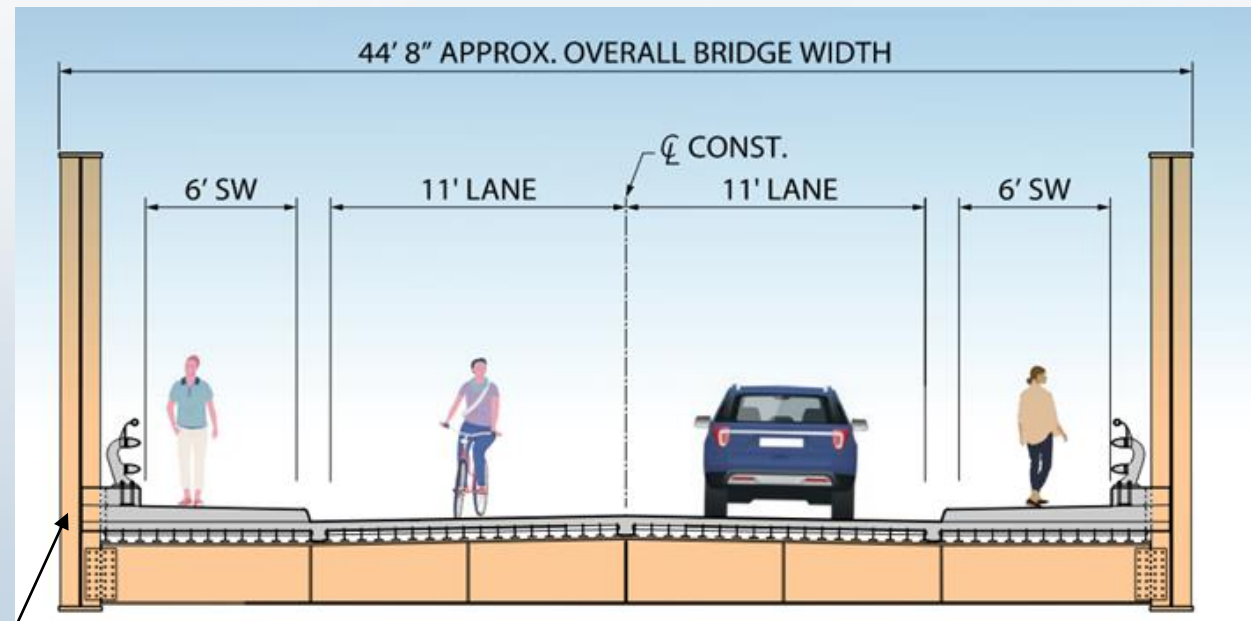

Bridge Girder  
or Truss

Two-Lane Bridge with Two Sidewalks Option

# HORIZONTAL ALIGNMENT

## The PD&E initially considered two alignment options:

### Existing Alignment

- Minimizes Right-of-Way and Park impacts
- Avoids a series of curves in the road
- Requires a temporary bridge to construct while maintaining traffic

### North Alignment

- Maintains traffic on the existing bridge through the majority of construction
- Construction takes place mostly offline of the existing road
- Shift to the north impacts the Park
- Shift to the north increases permanent environmental impacts

Following the first two alternatives public meetings and public input, the North Alignment for the replacement bridge was dropped from consideration due to greater permanent impacts to the parks and environment.

The North alignment remains under consideration for the temporary bridge.

# VERTICAL ALIGNMENT

- Profile options are limited by adjacent driveways
- Potential Clearances:
  - 14 feet vertical clearance on Existing Alignment
  - The new roadway is approximately 5' - 5'6" higher than the existing at bridge ends

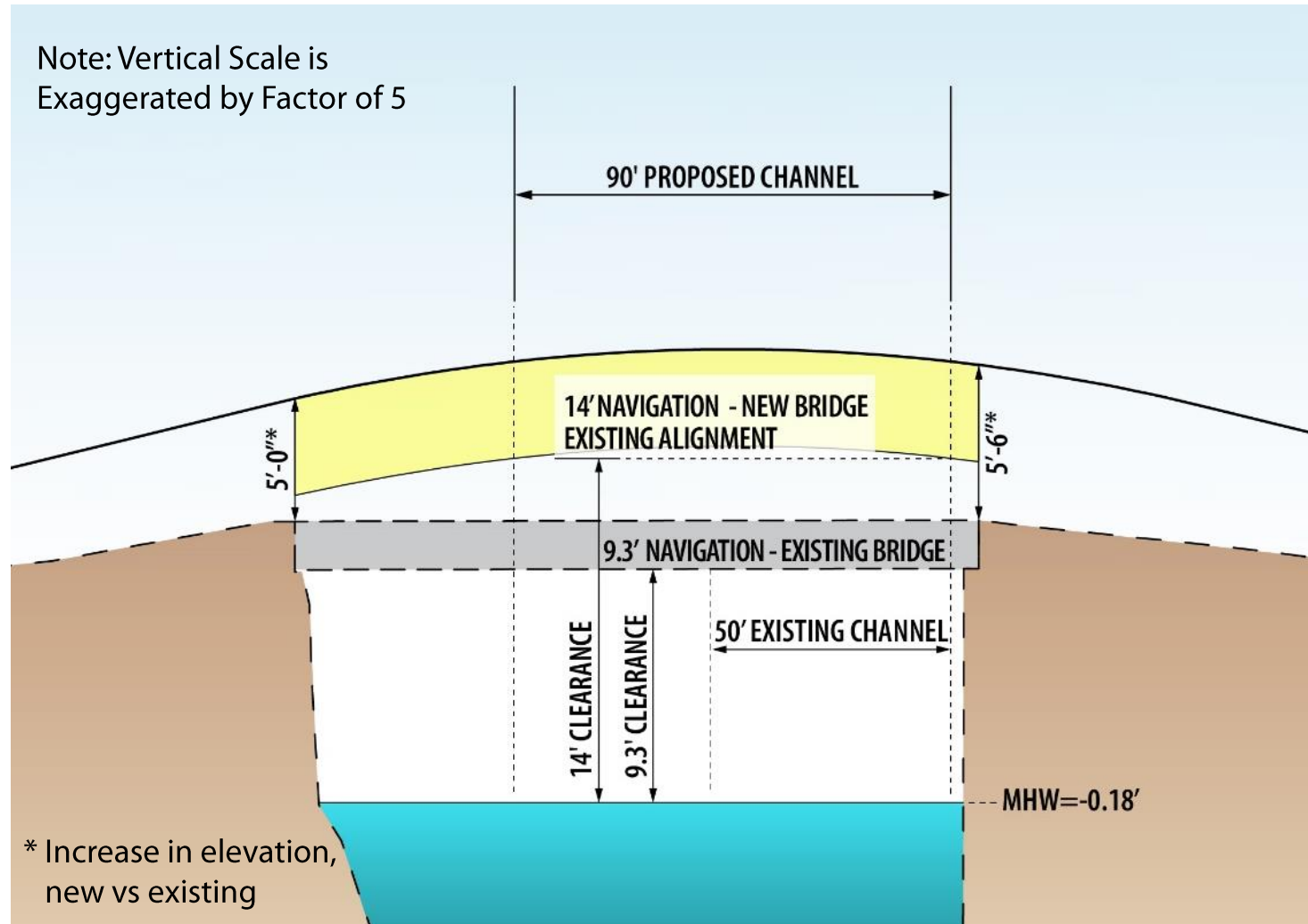

## Opportunity for Reduction in Bridge Openings with New Bridge

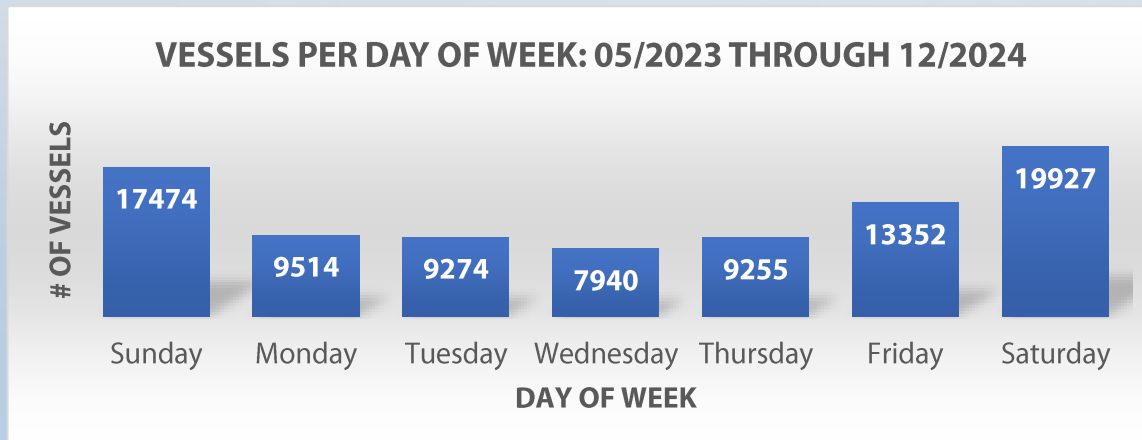
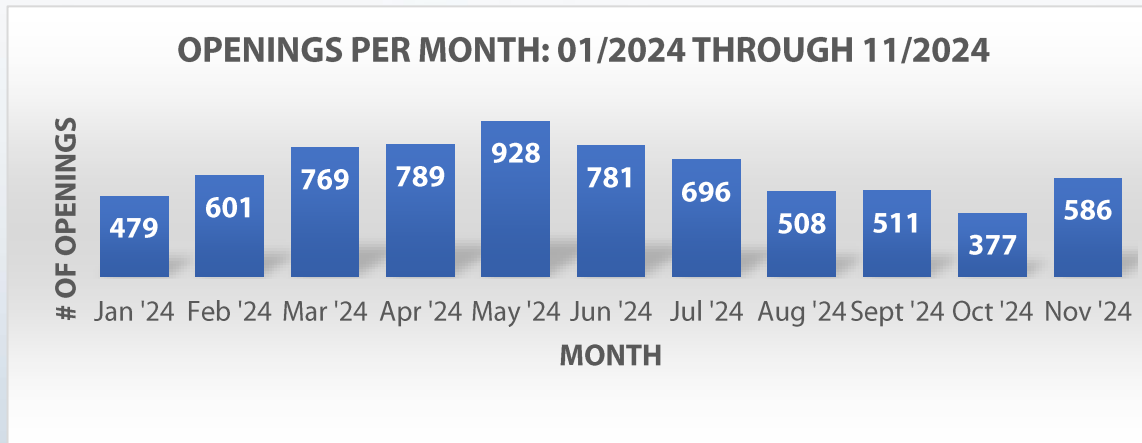

Effect of Increased Vertical Clearance on Bridge Openings

	12 Feet	14 Feet	16 Feet	21 Feet
Bridge Clearance	12 Feet	14 Feet	16 Feet	21 Feet
% Reduction in Openings	31%	48%	62%	78%

Proposed

Sarasota County worked with US Coast Guard to reduce openings. Effective August 12, 2024, from 7am to 7pm the bridge need only open on the hour, 20 minutes after the hour, and forty minutes after the hour, except weekends and holidays.

### **Bridge types under consideration:**

- Single-lane Options with one sidewalk on the south side:
  - Single-leaf bascule bridge
  - Swing span
- Two-lane Options with one sidewalk on the south side:
  - Single-leaf bascule bridge
  - Swing span
- Two-lane options with two sidewalks, one on each side:
  - Single-leaf bascule bridge
  - Swing span

## BRIDGE TYPES - SWING SPAN

Bob-tailed configuration (long span over channel, shorter back span) reduces movable span length

East pivot minimizes impacts to Blackburn Park and locates machinery on the mainland side

Resiliency Challenges:

- Pivot machinery is below deck level
- Close to splash zone
- Difficult to access for maintenance

Vulnerability Challenges:

- Requires large fender system to protect swing span from vessel impact when open

Construction challenges:

- Requires a temporary bridge (of limited salvage value) to construct on the existing alignment

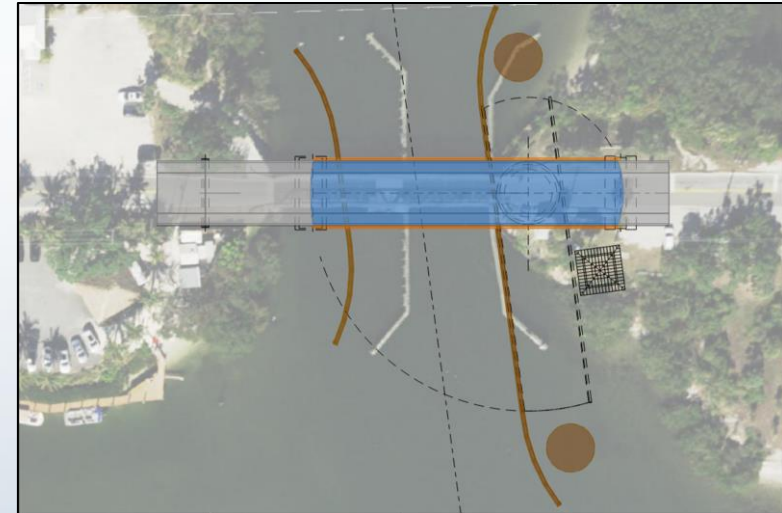

Pivot east of channel,  
existing alignment



# SINGLE-LANE SWING SPAN / ONE SIDEWALK



# TWO-LANE SWING SPAN / ONE SIDEWALK



# TWO-LANE SWING SPAN / TWO SIDEWALKS



# BRIDGE TYPES - BASCULE MOVABLE SPAN

Compared to the swing bridge options:

- Smallest movable span length
- Most resilient:
  - Maximum clearance above the water
  - Most durable with operating machinery located above the splash zone
  - Machinery is easily accessible without going below deck
  - Counterweight and machinery located on the east abutment
- Minimizes impacts to Blackburn Park
- Can be constructed to the north then slid to the existing alignment after existing bridge is removed – this avoids the cost of a separate temporary movable span

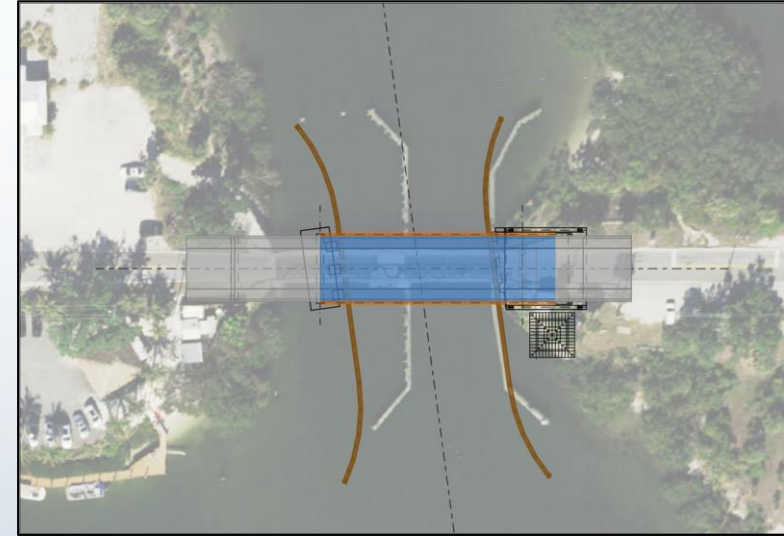

Existing alignment

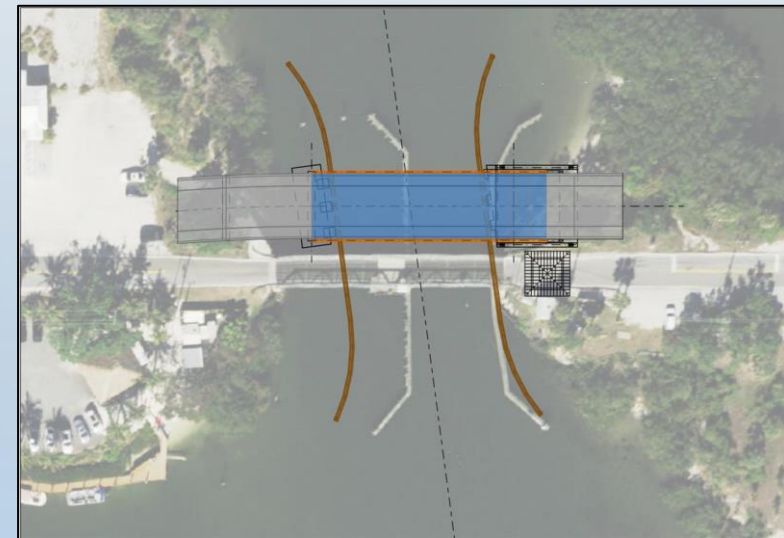

North (Temporary) alignment

# SINGLE-LANE BASCULE SPAN / ONE SIDEWALK



# TWO-LANE BASCULE SPAN / ONE SIDEWALK





# TWO-LANE BASCULE SPAN / TWO SIDEWALKS



# SINGLE-LANE BRIDGE/ TRAFFIC ANALYSIS / 2026 TRAFFIC VOLUME



## LEGEND

-  Controlling Queue
-  Secondary Queue



# SINGLE-LANE BRIDGE/ TRAFFIC ANALYSIS / 2026 TRAFFIC VOLUME



## LEGEND

-  Controlling Queue
-  Secondary Queue



# SINGLE-LANE BRIDGE/ TRAFFIC ANALYSIS / 2026 TRAFFIC VOLUME

## LEGEND

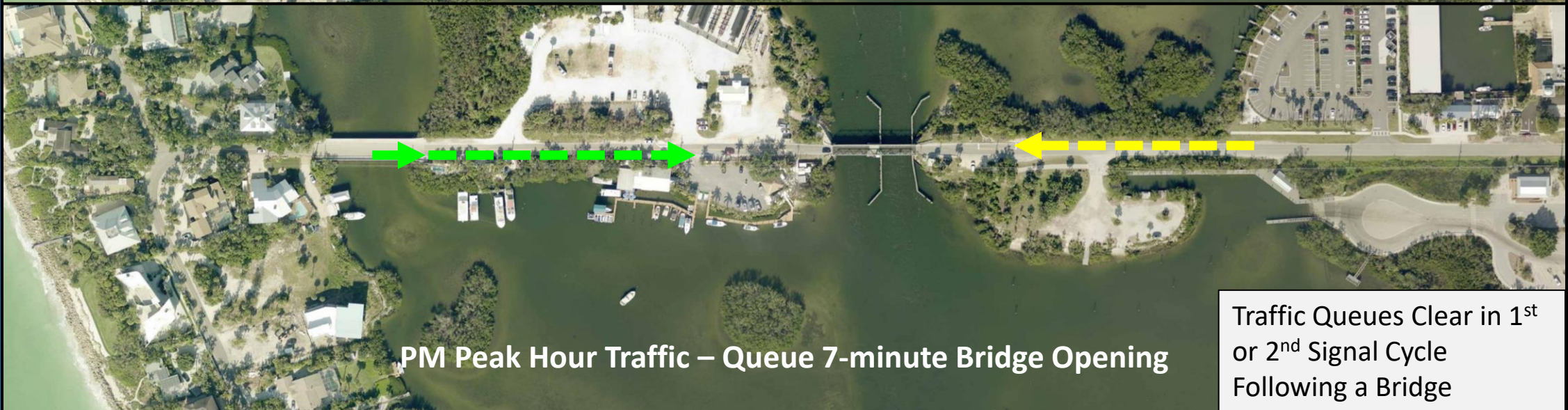
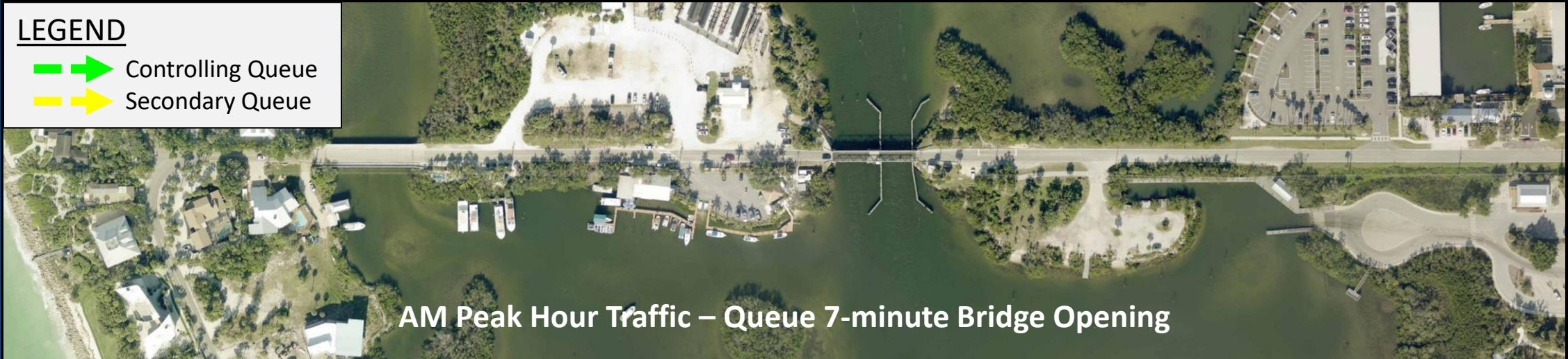

-  Controlling Queue
-  Secondary Queue



Traffic Queues Clear in 1<sup>st</sup> or 2<sup>nd</sup> Signal Cycle Following a Bridge Opening

# SINGLE-LANE BRIDGE / TRAFFIC ANALYSIS / 2050 TRAFFIC VOLUME

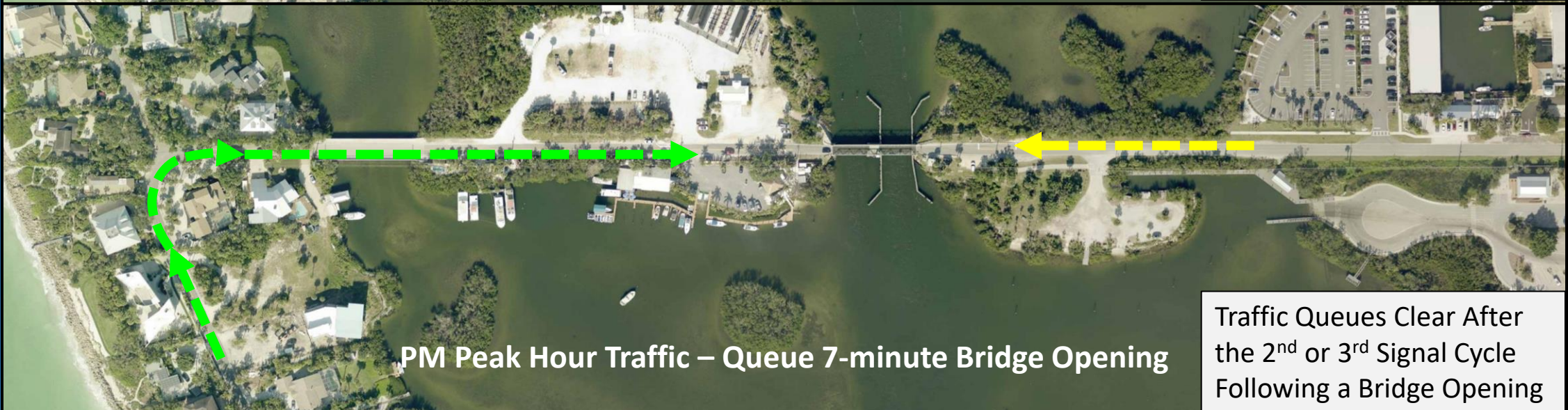

## LEGEND

-  Controlling Queue
-  Secondary Queue



# SINGLE-LANE BRIDGE / TRAFFIC ANALYSIS / 2050 TRAFFIC VOLUME



## LEGEND

-  Controlling Queue
-  Secondary Queue



# SINGLE-LANE BRIDGE / TRAFFIC ANALYSIS / 2050 TRAFFIC VOLUME

## LEGEND

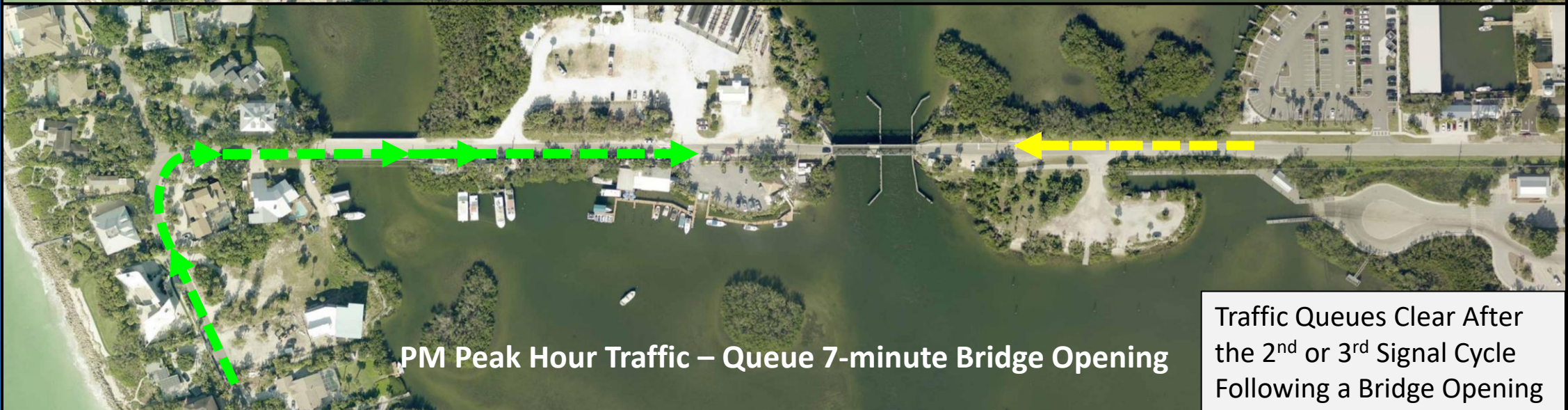

-  Controlling Queue
-  Secondary Queue



Traffic Queues Clear After the 2<sup>nd</sup> or 3<sup>rd</sup> Signal Cycle Following a Bridge Opening

## TWO-LANE BRIDGE TRAFFIC ANALYSIS / 2050 TRAFFIC VOLUME

### LEGEND

-  Controlling Queue
-  Secondary Queue



Two-Lane Bridge  
Without signaled  
directional traffic control,  
traffic queues clear after  
each bridge operation



# HONORING THE HISTORIC BRIDGE

## Potential mitigation measures

View from Blackburn Point Road

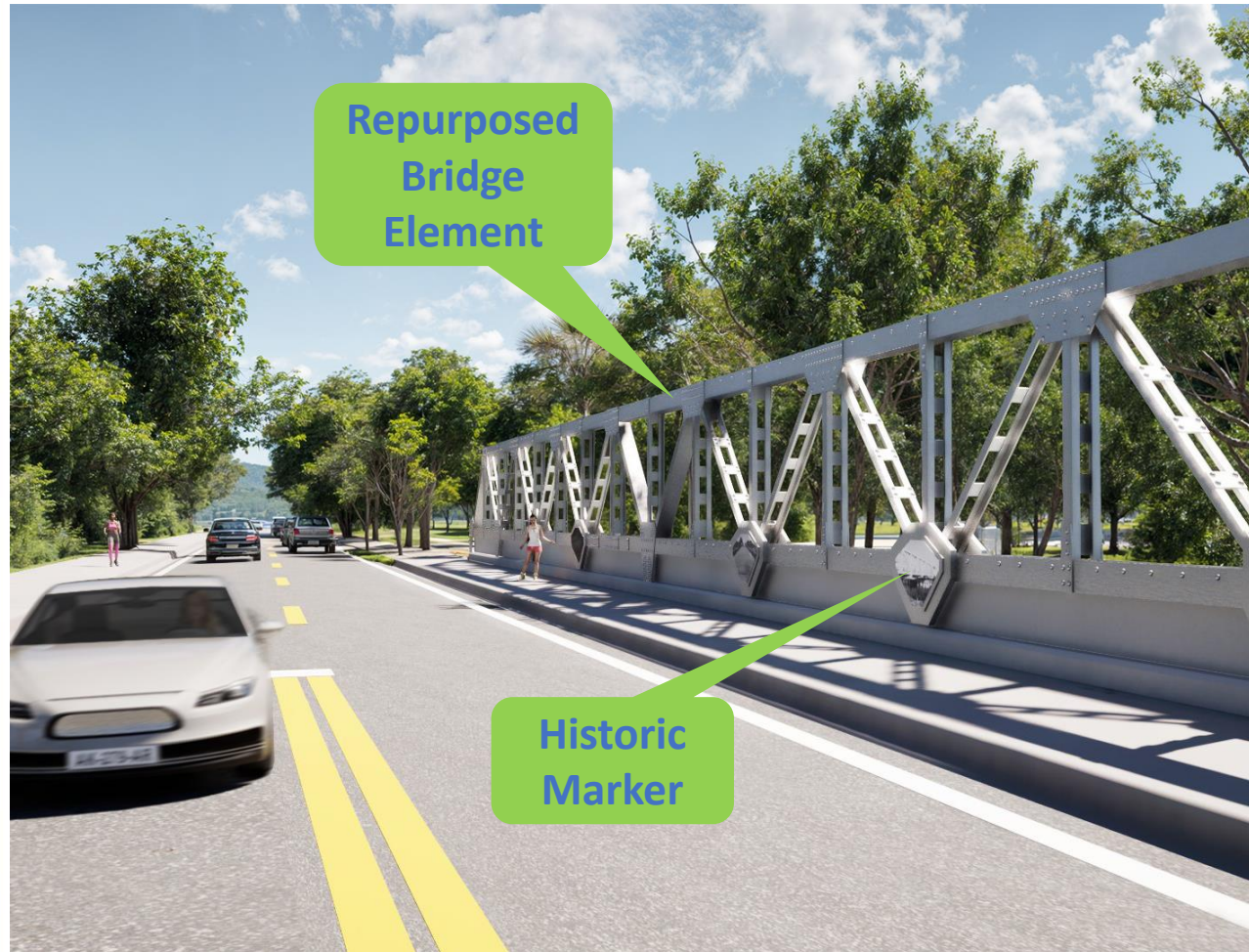

View from Sidewalk Behind Element



# POTENTIAL LOCATIONS FOR REPURPOSED EXISTING BRIDGE ELEMENTS / HISTORIC MARKER



**LEGEND**

- A** Roadside Truss
- B** Park Area Entrance
- C** Bridge Gateway
- D** Parkside Truss

# BRIDGE ALTERNATIVES ASSESSMENT MATRIX

BRIDGE ALTERNATIVES ASSESSMENT MATRIX											
Alternative	Sub Alternative	Cost Ratio	Environmental Impacts	Multi-Modal Accessibility	Constructability	Bridge Clearance	Bridge Width	Coastal Vulnerability	Safety	Historical Resource Impact	Assessed Value Totals
<b>No-Build</b>		<b>1.0</b>	<b>1</b>	<b>4</b>	<b>1</b>	<b>4</b>	<b>4</b>	<b>4</b>	<b>4</b>	<b>1</b>	<b>23</b>
<b>Single-Lane Bridge Alternatives:</b>	<b>Bascule with 1 sidewalk</b>	<b>1.2</b>	<b>2</b>	<b>3</b>	<b>2</b>	<b>1</b>	<b>3</b>	<b>1</b>	<b>2</b>	<b>3</b>	<b>17</b>
	<b>Swing with 1 sidewalk</b>	<b>1.6</b>	<b>2</b>	<b>3</b>	<b>4</b>	<b>1</b>	<b>3</b>	<b>2</b>	<b>2</b>	<b>3</b>	<b>20</b>
<b>Two-Lane Bridge Alternatives:</b>	<b>Bascule with 1 sidewalk</b>	<b>1.3</b>	<b>3</b>	<b>2</b>	<b>2</b>	<b>1</b>	<b>2</b>	<b>1</b>	<b>1</b>	<b>4</b>	<b>16</b>
	<b>Swing with 1 sidewalk</b>	<b>1.7</b>	<b>3</b>	<b>2</b>	<b>4</b>	<b>1</b>	<b>2</b>	<b>2</b>	<b>1</b>	<b>4</b>	<b>19</b>
	<b>Bascule with 2 sidewalks</b>	<b>1.5</b>	<b>4</b>	<b>1</b>	<b>2</b>	<b>1</b>	<b>1</b>	<b>1</b>	<b>1</b>	<b>4</b>	<b>15</b>
	<b>Swing with 2 sidewalks</b>	<b>1.8</b>	<b>4</b>	<b>1</b>	<b>4</b>	<b>1</b>	<b>1</b>	<b>2</b>	<b>1</b>	<b>4</b>	<b>18</b>

**TABLE NOTES:**

- a. Rankings in each category are from 1 (best value) to 4 (least value)
- b. Cost Ratio is the cost of each alternative divided by the present value of the repair costs followed by replacement

# PROJECT SCHEDULE



PD&E Study Project Schedule

## COMMENT & CONNECT

To submit comments, sign-up for email updates or for additional information, please visit the project website at:

**[BlackburnBridgeProject.com](http://BlackburnBridgeProject.com)**

or email comments or questions to:

**[capitalprojectsmeetings@scgov.net](mailto:capitalprojectsmeetings@scgov.net)**

or call 941-861-5000



# COMMENTS & QUESTIONS

## Open Discussion of Project, Community Comments and Questions

